

ART. 460-CSA Contatto magnetico in alluminio con elevate distanze operative, cavo 1,2 m
Aluminium magnetic contact with high operational distances, 1.2 m cable

ART. 460-TF-2 Come 460-CSA con cavo 2 m / Like 460-CSA with 2 m cable

SPECIFICHE GENERALI
GENERAL SPECIFICATIONS

Materiale contenitore Housing material	Alluminio pressofuso Die-cast aluminium
Funzionamento Operation	NC con i due componenti vicini NC when the two components are near
Temp. di funzionamento Operating temperature	-25°C ÷ +50°C
Grado di protezione IP degree	Certificato IPx2 (dichiarato IP65 da Cooper CSA) Certified IPx2 (declared IP65 by Cooper CSA)
V max	42,4 Vpeak - 60 Vdc
I max	1 A
W max	10 W
Identificazione Identification	Numero seriale/lotto su ogni componente Serial number/batch on each component

I contatti magnetici sono componenti passivi, le grandezze elettriche indicate sono le massime applicabili
Magnetic contacts are passive components, max applicable voltage and current are displayed in table

EN50131-2-6

GR 2

CL III



INSTALLAZIONE CONFORME ALLA NORMA
INSTALLATION AS PER STANDARD

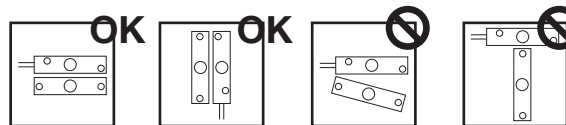
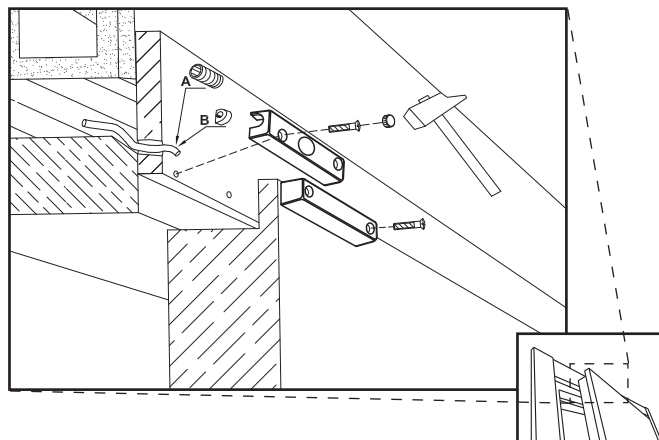

La certificazione decade per installazioni diverse da quelle rappresentate nelle figure.
Certification is void if the devices are installed differently.

DISTANZE OPERATIVE / OPERATIONAL APPROACH AND REMOVAL DISTANCES

Su superfici non ferromagnetiche installare i due corpi a distanza Y inferiore a 21mm (distanza raccomandata 5mm), su superfici ferromagnetiche a distanza Y inferiore a 14mm (distanza raccomandata 4mm). Le distanze operative riportate in tabella per gli assi X e Z sono state calcolate con i corpi installati alla distanza raccomandata.

Install the two components at Y distance less than 21mm (recommended 5mm) on non-ferromagnetic surfaces, at Y distance less than 14mm (recommended 4mm) on ferromagnetic surfaces. The operating distances displayed in table for axes X and Z have been calculated with the components mounted at the recommended distance.

Asse / Axis	Z+		Z-		X+ / X-		Y	
Azione Action								
Contatto Contact								
Superfici non ferromagnetiche Non-ferromagnetic surfaces	14 mm	22 mm	42 mm	60 mm	18 mm	33 mm	21 mm	33 mm
Superfici ferromagnetiche Ferromagnetic surfaces	14 mm	20 mm	20 mm	28 mm	14 mm	20 mm	14 mm	23 mm
Tolleranze / Tolerance	-0% +30%	+0% -30%	-0% +30%	+0% -30%	-0% +30%	+0% -30%	-0% +50%	+0% -30%

INDICAZIONI DI FISSAGGIO / FIXING INSTRUCTIONS

Fissare i componenti tenendo conto delle distanze operative riportate in tabella. Utilizzare viti autofilettanti $\varnothing 3,5 \div 3,9$. Inserire i tappi a protezione delle viti di fissaggio.

Fix the elements paying attention to the operational approach and removal distance. Use $\varnothing 3.5 \div 3.9$ tapping screws. Insert the plugs to protect screws.

COLLEGAMENTO / WIRING

